

Notes and safety instructions

English

Follow the attached mounting instructions.



Read the instructions carefully before installation and commissioning!



Leave the instructions for users/customers for future reference!



Our updated product documentation can be accessed at www.erco.com/download.

General safety information



Warning!

Risk of electric shock!

- Before carrying out maintenance and installation on the luminaire, disconnect from the mains supply and also from any other DALI control wiring, and ensure that all power is switched off.
- Never operate luminaires with damaged connection cables.



Caution!

Blue light hazard!



Position the luminaire marked with one of two adjacent pictograms so that extended gazing into the luminaire from a distance of less than xm is not expected. Find the value for x in the included graphic installation instructions.

Attention!

- In case of damage or a defective LED module, the entire luminaire must be returned to the factory.
- When installing, always observe the national installation and accident prevention regulations.

Intended use

The luminaire is suitable for use in dry interiors only.

Choosing the mounting location



Luminaire not suitable for covering with thermal insulation material.

- Lateral air space under EN 60598: The lateral distance between the surface of the luminaire and any parts of the building must be no less than 50mm.
- Recess depth according to EN 60598: Any necessary minimum distance between the uppermost surface of the luminaire and any parts of the building can be found in the mounting instructions.
- Position the luminaire so as to avoid operation in direct sunlight or near other sources of heat. High ambient temperatures can reduce the life and efficiency of the control gear or LED module.

Electrical installation

- Position the control gear as far from the luminaire as possible. Avoid crossing cables.

- Do not disconnect the electrical connection between the luminaire and control gear! This can cause damage to the luminaire and/or the control gear.

- For 3-circuit installation: to avoid any damage to the control gear, the neutral conductor must never be connected or disconnected during operation.

Overvoltage protection

ERCO uses electronic control gear with overvoltage protection in accordance with DIN EN 61547. If additional protection from spikes is required, e.g. when switching off inductive loads, separate overvoltage protection units should be installed.

Luminaire with DALI control gear

- All cables, materials and devices used must be suitable for mains voltage, as the DALI signal is not transmitted using safety extra low voltage (SELV).

- For general information on DALI, please go to: www.digitalilluminationinterface.org.

Push Dim

DALI luminaires whose DA connections are additionally marked "N" and "Push" can be controlled directly with a commercially available push-button (N.O. contact). For details see www.erco.com/pushdim.

RGBW luminaires

By combining red, green and blue colour mixing with warm white LEDs at different dimming levels, all colours, shades and colour temperatures can be created. To control the colours via a DALI system with colour management, the signal input has a DALI interface with an address for the luminaire. When operated using a system without colour management, 3 addresses per luminaire are used.

The colour compensation guarantees that exactly the same colour of light is obtained from all controlled luminaires which have the same DALI control settings.

Tunable white

Control of the tunable white component only via the DALI system with colour management (device type-8). Other systems can only dim but not control the light colour.

Luminaires with Casambi Bluetooth control

- For control of the luminaire you need a Bluetooth 4.0-capable smartphone or tablet and the Casambi app for iOS or Android downloadable for free in the specific app stores.

- You can couple up to 127 luminaires in a Casambi mesh network. This number can be increased via several parallel networks.

- Because the switching signal in a mesh network is transferred from luminaire to luminaire, the spacing between two luminaires must not exceed 10m.

This distance may be less according to the environment. For this reason you should check possible spacing between the luminaires prior to installation.

- ERCO GmbH hereby declares that the luminaires with Casambi control are compliant to Directive 2014/53/EU. Radio operation is implemented on frequency bands 2402 – 2480MHz with maximum transmission power of 4dBm. The complete text of the EU declaration of conformity is available at the following internet address: www.erco.com/casambi-ce.

Mounting

- When using wallwashers and directional luminaires, ensure correct alignment of the luminaire.

- When handling the reflector use the enclosed protective glove.

Removal

Remove the luminaire in reverse order. Note: Carefully lift the luminaire out of the mounting ring using a screwdriver.

Flashing of the LED module

It is normal for the LED module to flicker when switching on and off.

Dimming

Depending on the version, the luminaire can be dimmed via suitable dimmers (trailing edge).

Trailing edge dimmers

Follow the manufacturer's installation instructions. For some products, the luminaire can only be switched on in the upper dimming range. Before installation and connection, check luminaire, control gear and dimmer combination for proper functioning of the dimmer, especially when using universal dimmers.

The use of dimmers which are unsuitable for LED drivers can damage the luminaire, control gear and/or the dimmer. No responsibility is accepted for the use of dimmers that are unsuitable for the luminaire.

Cleaning

Always clean carefully using a soft cloth and a commercially available, ph-neutral, alcohol-free, non-abrasive cleaning agent.

Disposal



In accordance with EU Directive WEEE (Waste Electrical and Electronic Equipment), luminaires must not be disposed of with other household waste. At the end of their life, luminaires must be taken to the appropriate local facility available for the disposal or recycling of electronic products.

Compar

Mounting instructions

Downlight Downlight oval wide flood Downlight oval flood Lens wallwasher

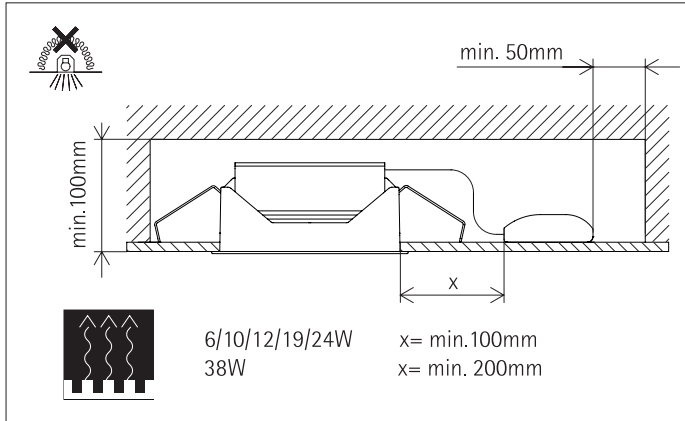

Oval flood



Oval wide flood

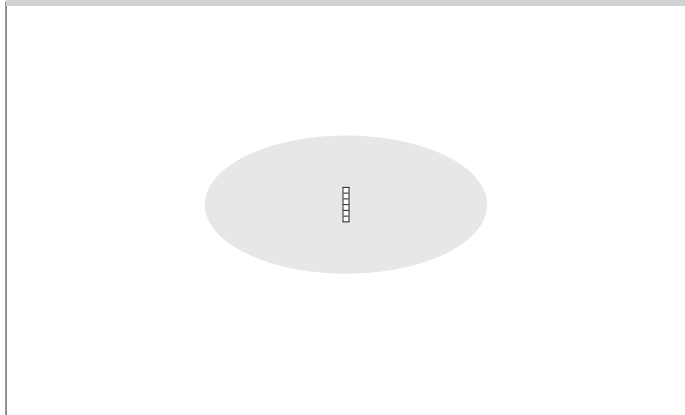

Downlight Downlight oval wide flood Downlight oval flood Lens wallwasher

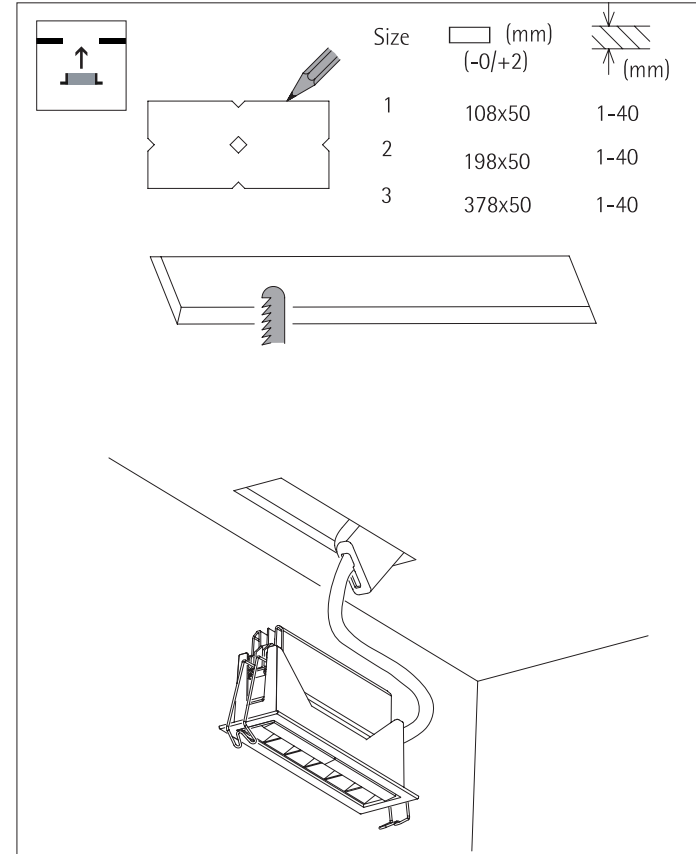

Lens wallwasher

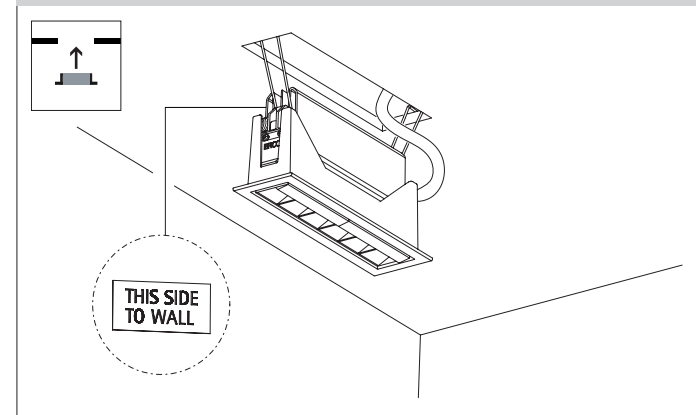

Downlight
Downlight oval wide flood
Downlight oval flood
Lens wallwasher

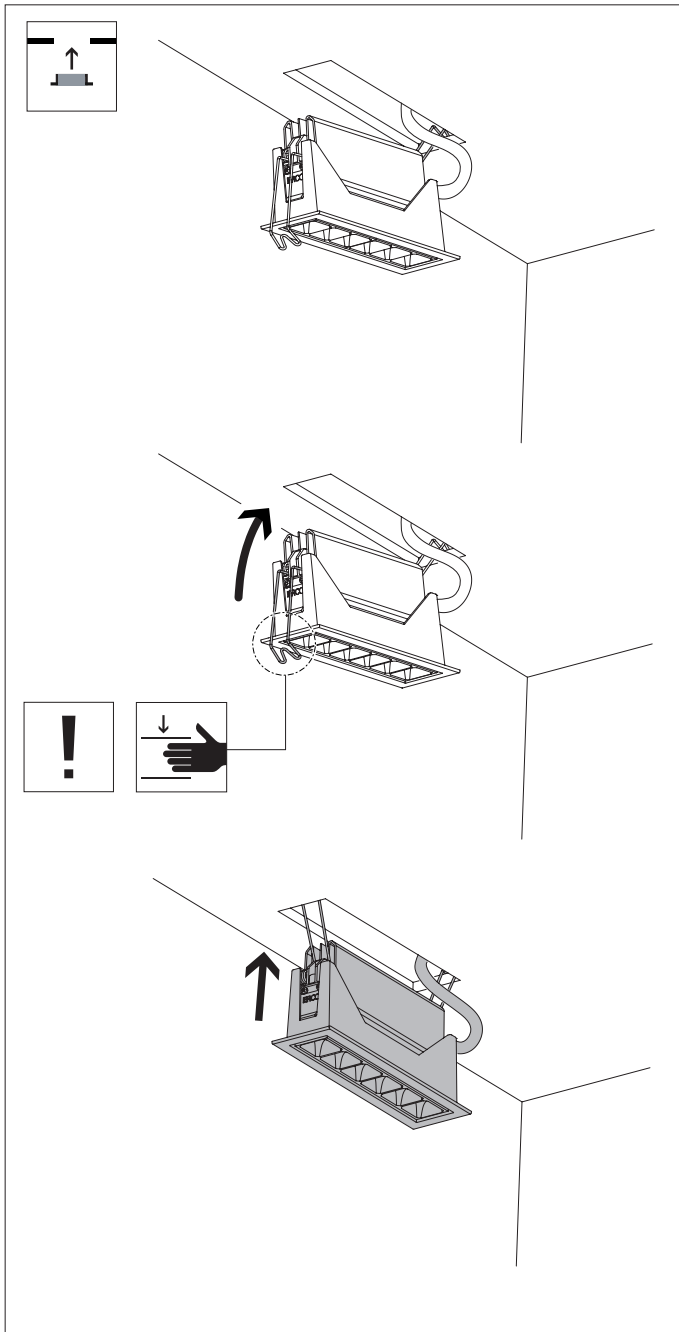

Downlight
Downlight oval wide flood
Downlight oval flood
Lens wallwasher

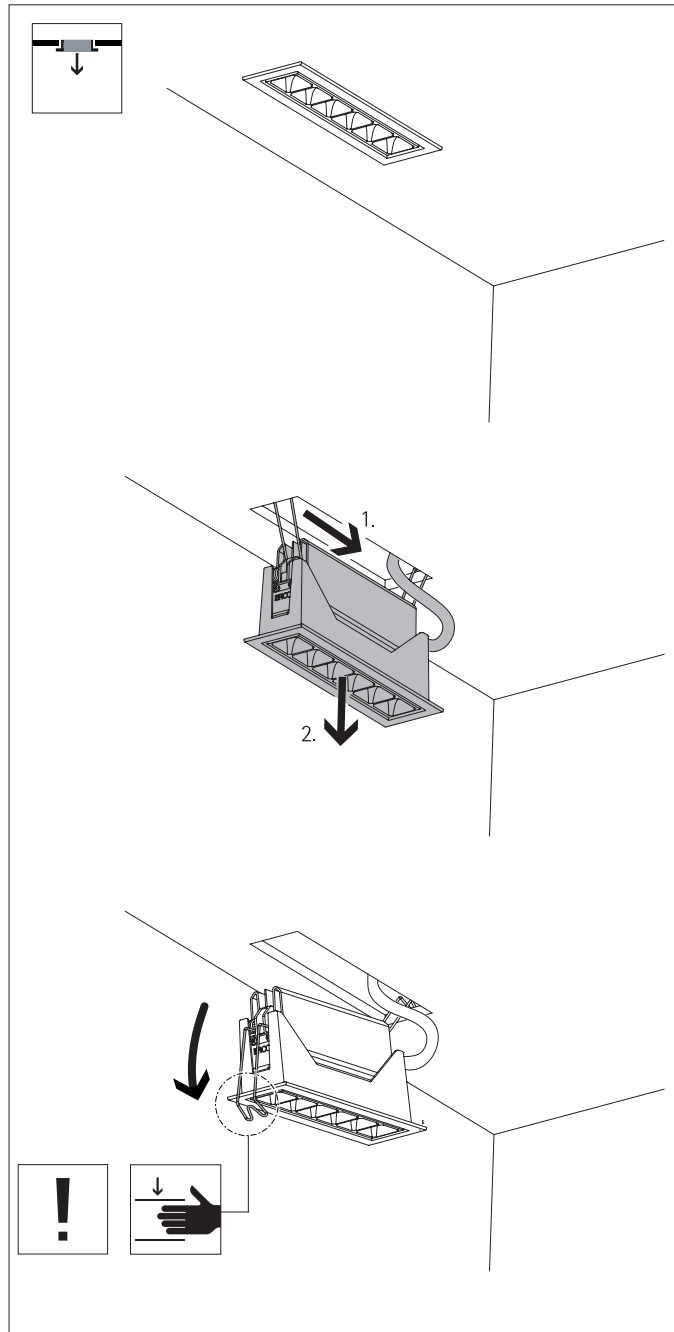

Downlight
Downlight oval wide flood
Downlight oval flood
Lens wallwasher

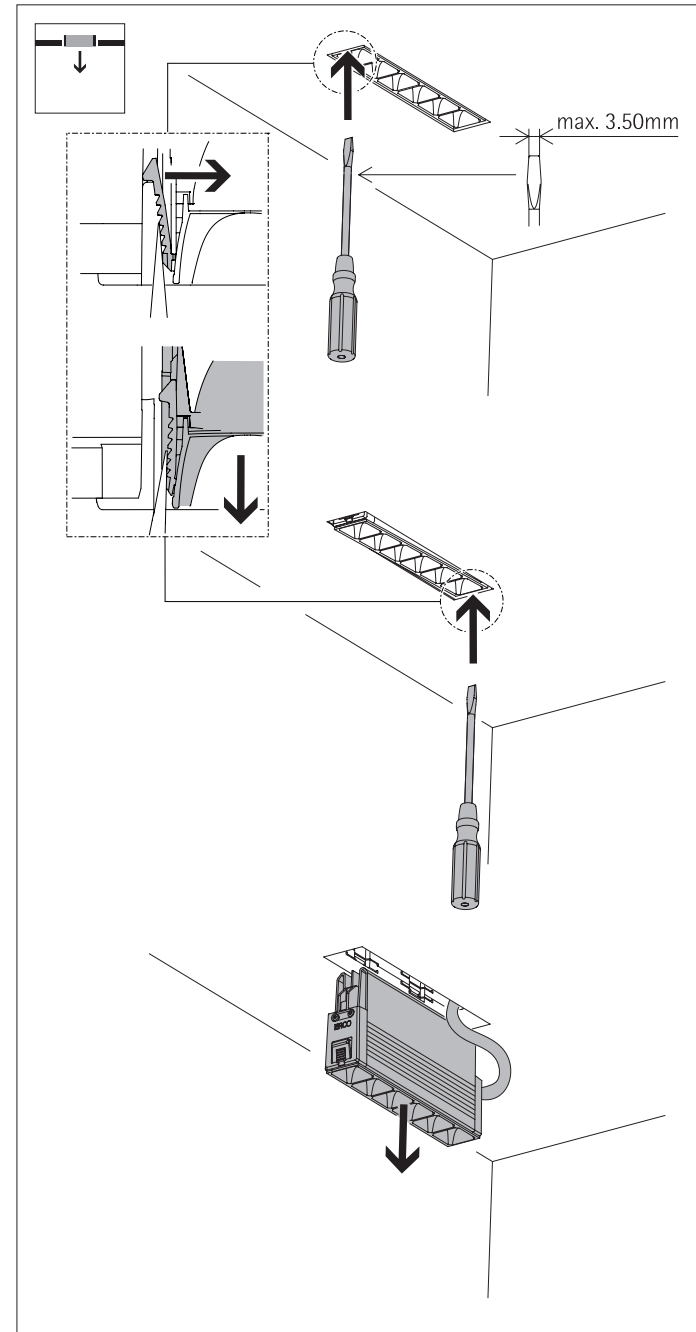

Spot 10W, 19W, 38W



CAUTION



x=min. 1.3m

Flood 10W, 19W, 38W



CAUTION



x=min. 0.75m

Oval wide flood 4000K / Oval flood 4000K



CAUTION



x=min. 0.5m

English

Follow the attached mounting instructions.