

Floor washlight

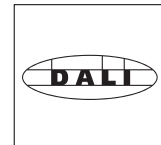
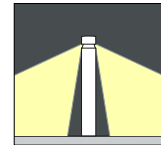
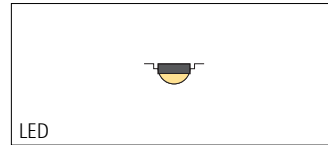
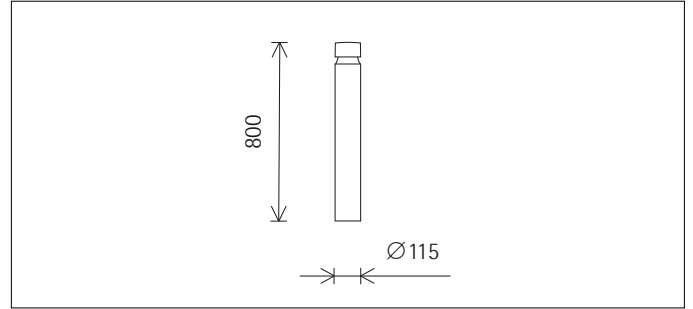

33913.999 Graphit m
LED 16W 1680lm 3000K warm white
DALI-2
Version 2

Product description

For mounting on accessories.
Bollard: corrosion-resistant aluminium profile, No-Rinse surface treatment. Double powder-coated. Optimised surface for reduced accumulation of dirt.
Upper cover and base plate: corrosion-resistant cast aluminium, No-Rinse surface treatment. Double powder-coated. Base plate for mounting on ground socket, concrete anchor or mounting plate.
ERCO DALI control gear. 2 cable entries.
Through-wiring possible. 4 terminals.
LED module: high-power LEDs on metal-core PCB.
360° light guidance ring made of optical polymer.
Anti-glare cone: corrosion-resistant cast aluminium, No-Rinse surface

treatment. double powder-coated and black lacquered.
Glare-free above the light aperture.
Mounting accessories to be ordered separately.
Protection mode IP65: dust-proof and water jet-proof.
Protection Class II
Weight 5.70kg
Housing temperature 56°C
Maximum wind load area 0.1m²
Version with 3000K CRI 97 or 2700K, 3500K, 4000K CRI 92 available on request.

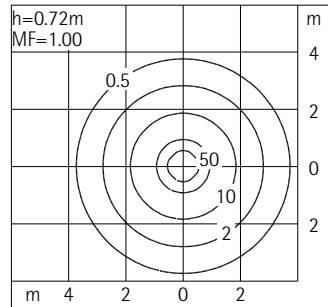
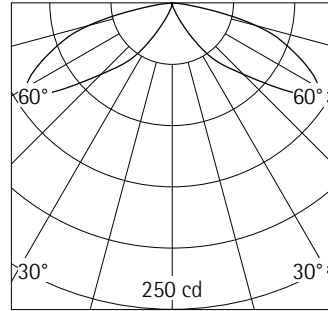

Technical data

Luminous flux of the luminaire	423lm
Connected load	18.0W
Luminaire efficacy	23lm/W
Colour deviation	1.5 SDCM
Colour rendition index	CRI 92
Lumen maintenance (LED manufacturer specifications)	L90/B10 ≤50000h L90 ≤100000h
LED failure rate	0.1% ≤50000h
Dimming range	1%-100%
Dimming method	CCR
LMF	E
Energy efficiency class	EEI A+
Standby power per control gear	0.15W
Luminaires per circuit breaker B16	32
Temperature on the light aperture	37°C

Planning data

Cleaning (a)	1				2				3			
	P	C	N	D	P	C	N	D	P	C	N	D
LMF	0.96	0.94	0.90	0.86	0.93	0.91	0.86	0.81	0.92	0.90	0.84	0.79
RSMF	0.97	0.95	0.91	0.86	0.97	0.94	0.90	0.86	0.97	0.94	0.90	0.86

Hours of operation (h)	1000	5000	10000	20000	30000	40000	50000
LLMF	1.00	0.99	0.98	0.96	0.94	0.92	0.90
LSF	1	1	1	1	1	1	1

MF	LMFxRSMFxLLMFxLSF
MF	Maintenance Factor
LMF	Luminaire Maintenance Factor
RSMF	Room Surface Maintenance Factor
LLMF	Lamp Lumens Maintenance Factor
LSF	Lamp Survival Factor
P	Room pure
C	Room clean
N	Room normal
D	Room dirty

Technical data in accordance with international norms and standards

IEC 60598	Luminaires – Part 1+2: general requirements, specific requirements and tests
IEC 62031	LED modules for general lighting – safety requirements
IEC 62471	Photobiological safety of lamps and lamp systems
EN 13032-4	Light and lighting – measurement and representation of photometric data
CIE 13	Method of measuring and specifying colour rendering properties of light sources

All technical data is subject to industrially standard tolerances.
Also see www.erco.com/erco-led

Accessories



34974.000
 Distribution box, IP68
 With four cable entries, 7-25mm.
 Polymer.
 ø 102mm, L 305mm.
 Weight 0.47kg
CE IP 68 3m

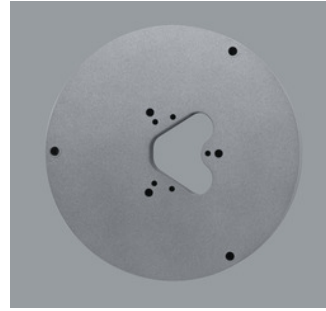

33982.000
 Mounting plate
 Corrosion-resistant cast aluminium,
 No-Rinse surface treatment. Graphit m,
 double powder-coated.
 Weight 1.70kg



33975.000
 Ground socket
 Metal, hot-dip galvanised.
 Weight 2.10kg

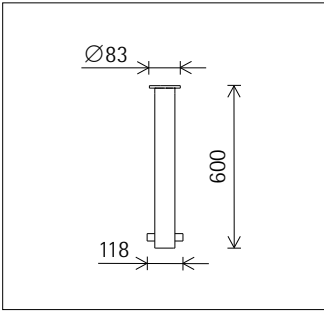
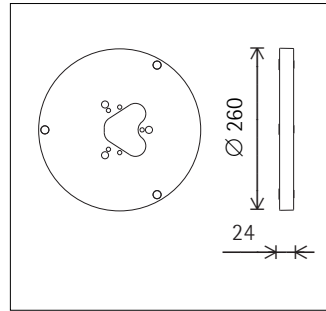

33979.000
 Concrete anchor
 Mounting plate with threaded bar and
 fixing nuts M6. Individual parts to be
 assembled on-site.
 Weight 0.25kg

